



REEL + TRANSFO + 329 LED LAMP



Spring-operated cable reel equipped with inspection lamp and transformer.

This model allows to have the lamps feeded at low voltage, as requested by the safety rules.

REEL FEATURES

See page 22

PORTABLE LAMP - 30 LEDS

- Ultra bright light.
- Low energy consumption.
- No development of heat.
- Electronic power circuit on the handle.
- Switch.
- Rotating hook.



Enrouleur automatique à ressort équipé de baladeuse et transformateur.

Ce modèle permet d'avoir les baladeuses alimentés à basse tension, comme prévu par les normes de sécurité.

CARACTERISTIQUES DE L'ENROULEUR

Voir page 22

LAMPE PORTATIVE A' 30 LED

- Lumière très blanche.
- Economie d'énergie.
- Ne chauffe pas.
- Circuit électronique d'alimentation dans la poignée.
- Interrupteur.
- Crochet pivotant.



Kabelaufroller mit Federantrieb, mit Handlampe und Trafo.

Dieses Modell erlaubt, die Lampe mit Niederspannung gemäß den Sicherheitsnormen zu versorgen.

EIGENSCHAFTEN AUFROLLER

Siehe Seite 23

HANDLAMPE MIT 30 LED

- Intensiv helles Licht.
- Minimaler Stromverbrauch.
- Keine Erwärmung.
- Elektronischer Versorgungsstromkreis im Handgriff.
- Schalter.
- Drehbarer Aufhängehaken.



Enrollador automático con rebobinado de resorte, lámpara portátil y transformador.

Esto modelo permite d'alimentar les lámparas en baja tensión, según norma de seguridad.

CARACTERISTICAS DE L'ENROLLADOR

Ver pag. 23

LAMPE PORTATIVE A' 30 LED

- Lúz ultra blanca.
- Mínimo consumo de energía.
- No se calienta.
- Circuito electrónico de alimentación en la empuñadura.
- Interruptor.
- Gancho giratorio.

SPARE PARTS-PIÈCES DE RECHANGE

ART. 529

- Plastic bell/Cloche/Glocke.

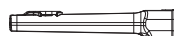

5908/329



Manufactured according to standard:
Construit selon norme:
EN 60598-1 EN 60598-2-8
EN 61242 EN 60335-1



These products comply with Directives:
Produits conformes aux Directives:
2006/95/CE 2006/42/CE
2002/95/CE

DIMENSIONS

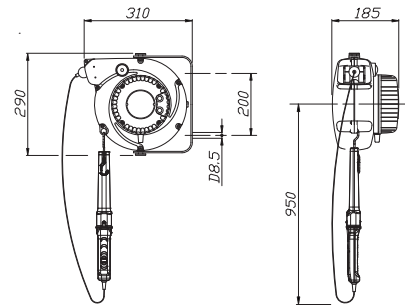

Art.	5908/329
Description	Cable reel with transfo + lamp 329 24V
m. coiled/m. enroulés	m 15,5 (14 + 1,5)
feeding cable/cable d'alimentation/Zuleitung	1 m
transfo features Trafo Merkmale	power: 25VA input: 230V output: 24V
cable type	HO5 RN-F
bulb/ampoule Bime/bombilla	YES (30 led)
lamp protection degree/ Lampe Schutzart	IP55
reel protection degree Aufroller Schutzart	IP42
voltages input entrée Eingang/entrada	230V
	44
	mm 345x305x230 Kg 6,0